

# MANUAL

# BT400-NEX-D

## INSTALLATION-OPERATION/MAINTENANCE INSTRUCTIONS AND PART LIST



Report #0459GH001S

UL 733-1993 (R2013)  
CSA B140.8-1967 (R2015)

[www.hermannelson.com](http://www.hermannelson.com)

100 Eagle Drive, Winnipeg, MB, R2R 1V5 CANADA

1 (800) 486-4328 // 1 (204) 633-1999

Sales@hermannelson.com

rev:4

**AEROTECH  
HERMAN  
NELSON**  
INTERNATIONAL INC.

# TABLE OF CONTENT

	PAGE #
<b>SECTION 1 INTRODUCTION</b>	
1.1 General	4
1.2 Scope	4
1.3 Safety Precautions	4
1.4 Moving Heaters while in operation	4
<b>SECTION 2 DESCRIPTIONS</b>	
2.1 General	5
2.2 Scope	5
2.3 Power Unit	5
2.4 Fuel System	5 & 6
2.5 Heat Exchanger	7
2.6 Cabinet	8
2.7 Trailer	8
2.8 Specifications	9
<b>SECTION 3 PREPARATIONS FOR USE AND STORAGE</b>	
3.1 General	10
3.2 Scope	10
3.3 Preparation for use	10
3.4 Preparation for storage	10
<b>SECTION 4 OPERATING INSTRUCTIONS</b>	
4.1 General	11
4.2 Scope	11
4.3 Theory of Operation	11
4.4 General Theory	11
4.5 Electrical System	11 & 15
4.6 Detailed Theory	12
4.7 Fuel System	12
4.8 Fuel Pump	12
4.9 Burner Control Valve	13
4.10 Temperature Control Valve	14
4.11 Thermostat	14
4.12 Discharge Temperature Gauge	14
4.13 Emergency Shut-Off Switch	14
4.14 12V Power Socket	14
4.15 Electrical System	16
4.16 Operating Instructions	16
4.17 Preliminary Adjustments	16
4.18 Operating Under Normal Circumstances	17
<b>SECTION 5 MAINTENANCE INSTRUCTIONS</b>	
5.1 General	18
5.2 Scope	18
5.3 Cleaning	18

# TABLE OF CONTENT

<b>SECTION 5 MAINTENANCE INSTRUCTIONS</b>	<b>PAGE #</b>
5.4 Flexible Ducts	18
5.5 Inspection and Preventive Maintenance	18 & 19
5.6 Battery	20
5.7 Battery Removal	20
5.8 Battery Installation	20
5.9 Fuel Filter	20
5.10 V-Belt	20
5.11 Heat Exchanger Assembly	21
5.12 Heat Exchanger Assembly Removal	21
5.13 Heat Exchanger Assembly Installation	21
5.14 Fan and Mounting Ring Assembly	21
5.15 Fan and Mounting Ring Removal	21
5.16 Fan and Mounting Ring Installation	21
5.17 Heat Exchanger	22
5.18 Heat Exchange Disassemble	22
5.19 Heat Exchange Reassemble	22
5.20 Carbon Monoxide Test	22
5.21 Heater Ignition System	22
5.22 Coil	22
5.23 Igniter Cable and Igniter Plug	23
5.24 Ignition Cable and Igniter Plug Removal	23
5.25 Ignition Cable and Igniter Plug Installation	23
5.26 Fuel Pump	24
5.27 Fuel Pump Adjustment	24
5.28 Fuel Pump Removal	24
5.29 Fuel Pump Installation	24
5.30 Troubleshooting	25 & 26
<b>SECTION 6 PART LIST</b>	
Figure 6-1 Heater	27
Figure 6-2 Heater	28
Figure 6-3 Heater Outlet	29
Figure 6-4 Fan Assembly	30
Figure 6-5 Heat Exchanger Assembly	31
Figure 6-6 Heater Engine Compartment	32
Figure 6-7 Heater Engine Compartment	33
Figure 6-8 Valves and Filters	34
Figure 6-9 Control Panel	35

# SECTION 1 - INTRODUCTION

---

## 1.1 General

## 1.2 Scope

These instructions are for use by personnel who have purchased the BT400-NEX-D heater manufactured by AEROTECH HERMAN NELSON INTL. INC. Contained within is the information on the operation and maintenance of the heater as well as the description of the major components and their functions in relation to other parts of the heater. In addition, a list of repair parts which may be required for maintaining the heater is provided in Section 6.

## 1.3 Safety Precautions

Precautionary measures to be taken during operation and maintenance of the heater are contained in the appropriate paragraphs of the manual. In addition, all safety precautions are listed in the front of this manual.

Listed below are the definitions of commonly used terms in this manual.

**DANGER:** You will be subject to serious injury or death if you fail to follow instructions!

**WARNING:** You could be subject to serious injury or death if you fail to follow instructions!

**CAUTION:** You can be hurt if you fail to follow instructions!

**NOTICE:** Your heater or other property could be damaged if you fail to follow instructions!

## 1.4 Moving Heaters While in Operation



It is strongly recommended by Aerotech Herman Nelson that our heaters **NOT BE MOVED WHILE IN OPERATION.** There is a possibility that the fuel being sloshed around inside the tank can leak out of the vents and come in contact with the flame in the combustion chamber causing a fire. The fuel pick up line in the tank may suck in air which will cause cavitation of the fuel pump, which will stall the engine; the flame in the combustion chamber will go out, causing the heat exchanger to warp due to lack of cooling air, which will decrease the life of the heat exchanger. If the engine has stopped because of the cavitation of the fuel pump, the fuel system will need to be bled to remove the air. When the fuel pump has no fuel the gears may become damaged introducing metal filings into the fuel system. These metal filings can then get into the engine causing major damage to a host of major components on your heater.

**Please Never Move Your Heater When In Operation**



# SECTION 2 - DESCRIPTIONS

---

## 2.1 General

## 2.2 Scope

The model BT400-NEX-D heater is a fully enclosed, portable, two wheeled trailer mounted unit, intended for use in ground heating maintenance shelters, portable hangers, aircraft engines and fuselages, and other similar enclosures.

## 2.3 Power Unit

The model BT400-NEX-D heater is supplied with a Kubota diesel engine. A drive coupling is attached to the drive shaft of the engine and is attached to a driven coupling by way of a flexible rubber sleeve. The driven coupling drives the heater fan through a pulley and the V-belt drives the fuel pump.

## 2.4 Fuel System

The heater uses a variety of fuel types.(table 2-2) Fuel is drawn from a 35 gallon fuel tank through a fuel filter by a belt driven fuel pump. Fuel flows through the nozzle contained in a holder with inlet and bypass fuel lines. As the fuel leaves the nozzle it is atomized and ignited by the igniter plug. Fuel is also bypassed from the nozzle, through a 5psi check valve, to the temperature control valve. This check valve prevents a reverse flow. A 25psi check valve is installed on the inlet side of the temperature control valve to maintain a minimum pressure so the fuel nozzle maintains a proper fuel spray pattern.

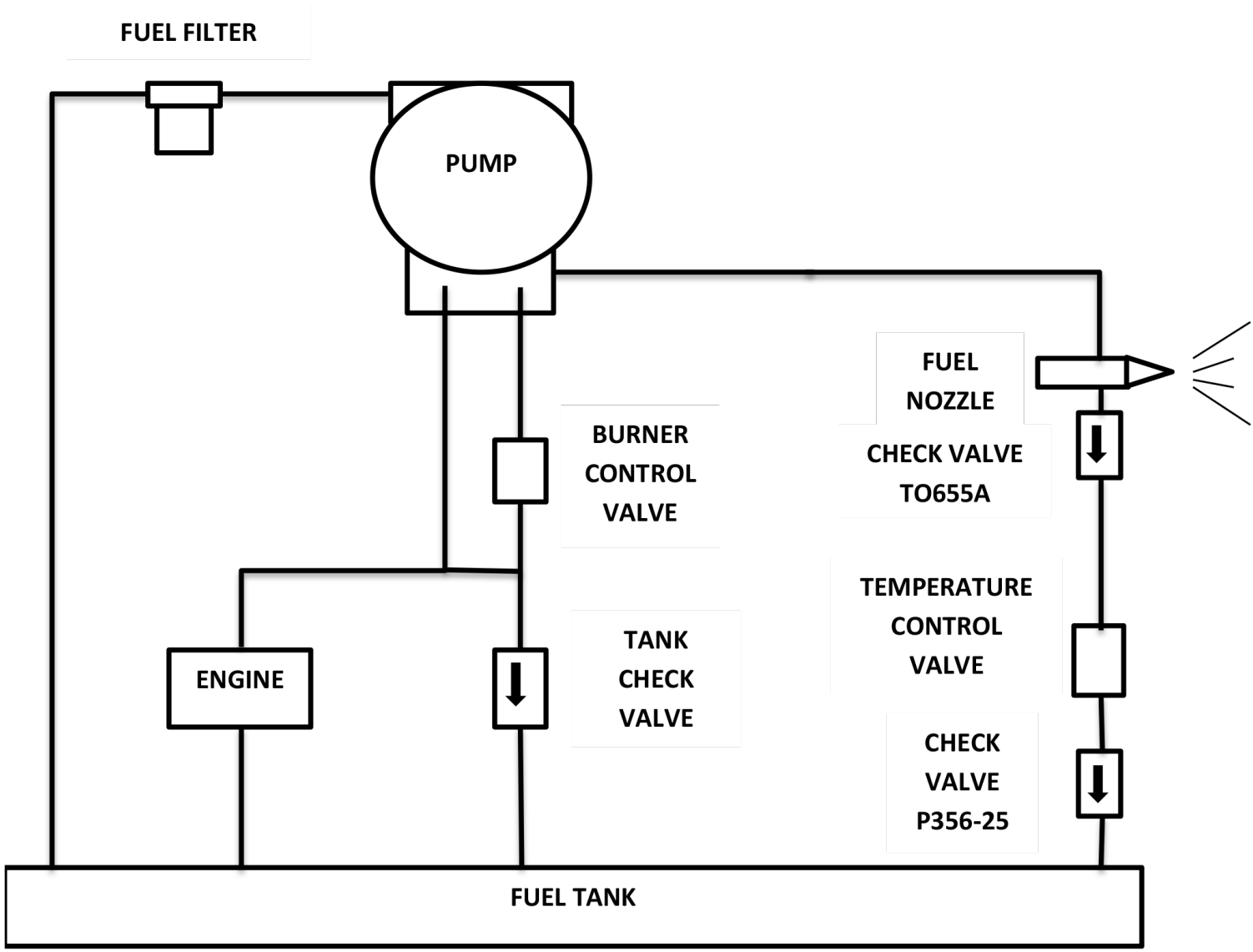
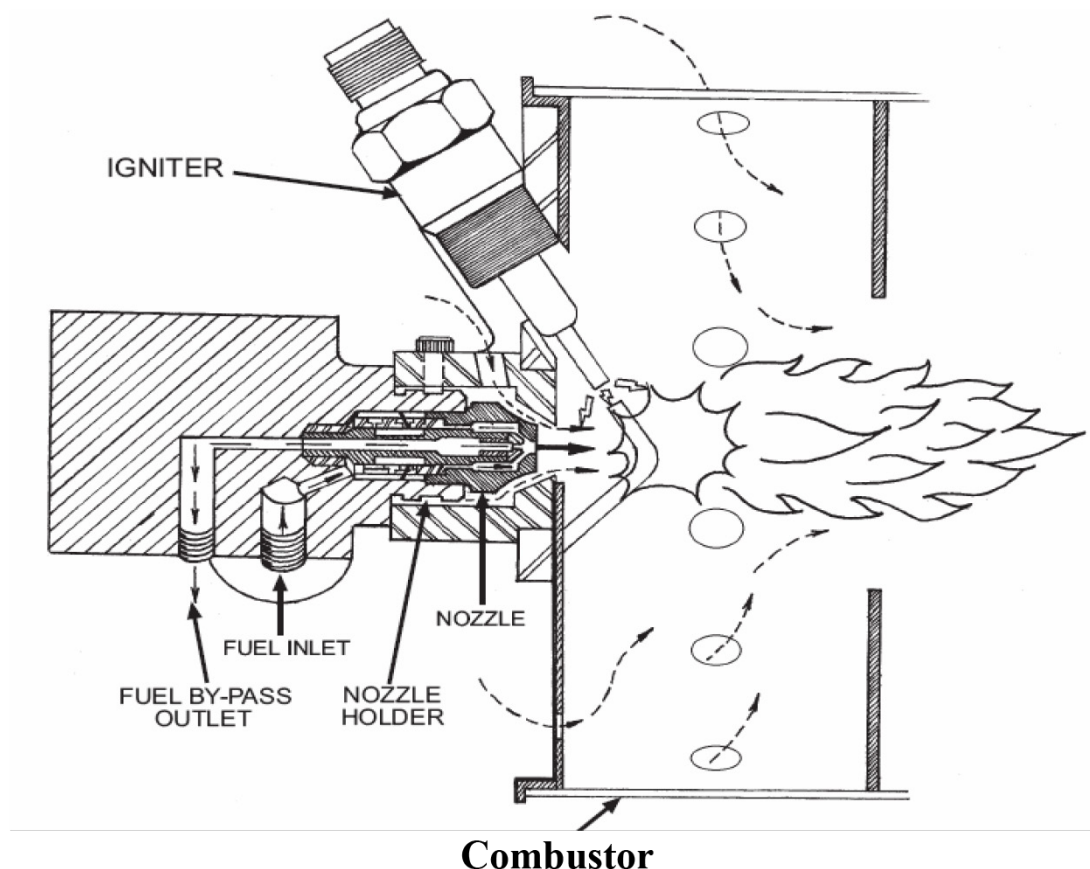

Figure 2-1 Heater Fuel System

## SECTION 2 - Con't

### 2.5 Heat Exchanger

Fuel flowing from the nozzle is ignited in the combustion chamber (see figure 2-2). The burning fuel strikes a plate or target in the combustor and is diffused into the heat exchanger. Air from the fan enters holes in the side of the combustor in a manner that will ensure proper fuel-air mixture. From the combustor, the burning fuel flows through the heat exchanger in a spiral path between the surfaces of the ventilating air tubes and is expelled through the parallel tubes and the space between the surfaces of the ventilating air tubes and is expelled through the exhaust opening at the top of the casing. (See figure 2-3)The ventilating or heating air is forced through the parallel tubes and the space between the heat exchanger shell and the casing. Heat is exchanged between the hot exhaust gases and the ventilation air. At the discharge end of the heat exchanger is the temperature sensing elements. The air control assembly consists of a baffle and a series of radial tubes. Air traveling between the walls of the heat exchanger and the casing is directed radially inward behind the baffle where it is mixed with warmer air leaving the parallel tubes of the heat exchanger. This mixing ensures a more uniform temperature throughout the discharge airstream. A duct adapter assembly is installed on the discharge end of the heater to connect the flexible duct.



**Figure 2-2 Sectional View of Nozzle & Combustor**

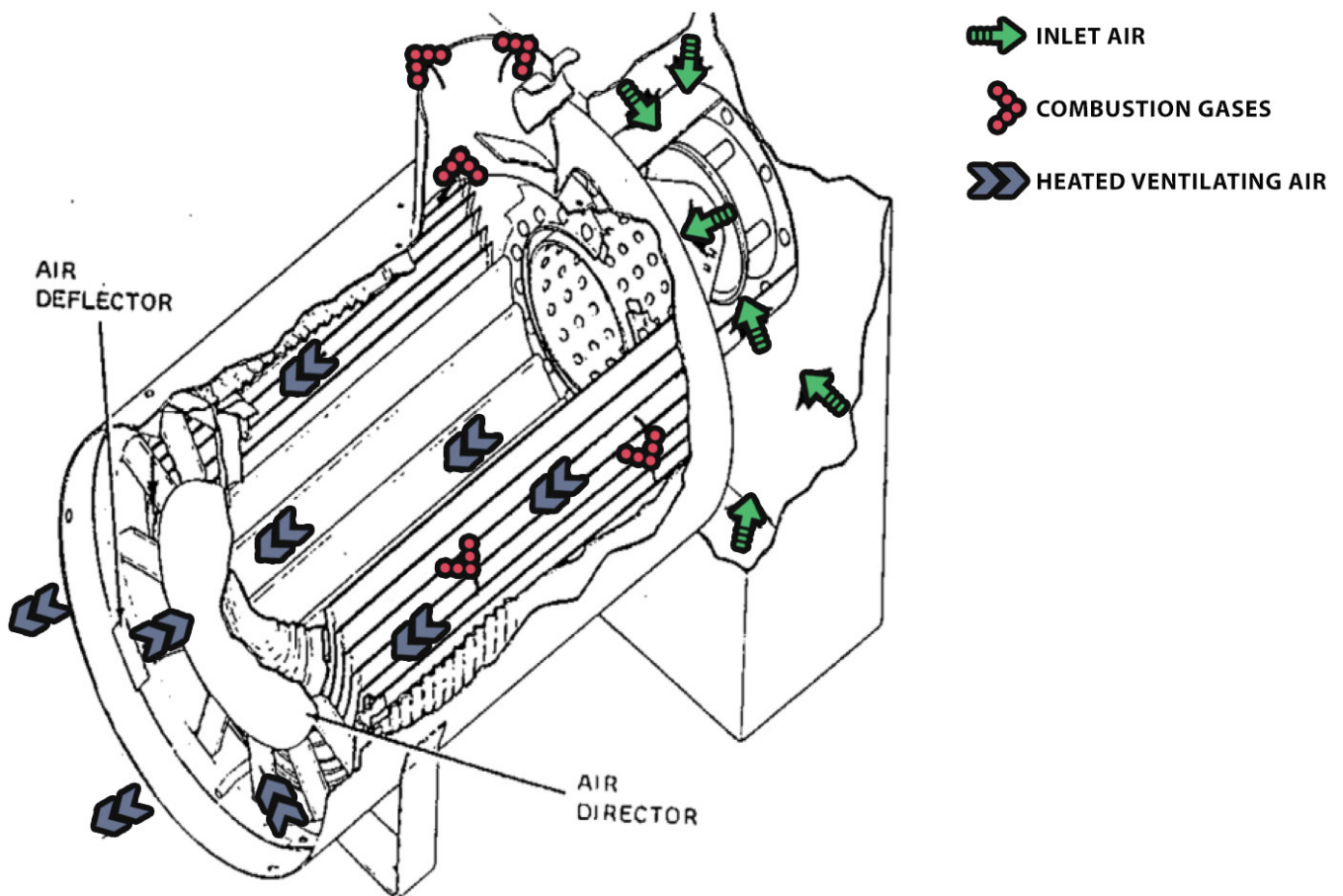

**Figure 2-3 Air Flow**

### 2.6 Cabinet

The engine is enclosed in a cabinet which provides protection against the elements and prevents damage during storage or transit. The cabinet is hinged to provide access to the engine and all other components for easy maintenance.

### 2.7 Trailer

The unit is constructed on a two-wheeled trailer to transport the heater from worksite to worksite. Duct holders hold the ducts when not in use. An adjustable tow bar serves as a support when the trailer is stationary.

**NOTE**

Do not exceed 20 mph when towing.

## SECTION 2 - Con't

### 2.8 Specifications

The BT400-NEX-D heater specifications are listed in Table 2-1.

Table 2-1 Specifications

LENGTH	72 inches
HEIGHT	53 inches
WIDTH	51 inches
DRY SHIPPING WEIGHT	710 lbs
ENGINE	Kubota
RATING	400,000 BTU
AIR OUTLET RANGE	150°F TO 280°F (66°C to 138°C)
AIR DELIVERY RATE	1500 CFM
FUEL TANK CAPACITY	35 gallons (132.5 liters)
ELECTRICAL	12 Volts DC
ENGINE OIL	0W-30 synthetic arctic oil

Table 2-2 Fuel Specifications

AMBIENT TEMPERATUR	SPECIFICATION	SYMBOL/ SPECIFICATION	REMARKS
-65°F (-54°C) & ABOVE	MIL-T-5624	JP-4-AIRCRAFT TURBINE FUEL	PRIMARY FUEL
-50°F (-46°C) & ABOVE	MIL-T-5624	JP-5-AIRCRAFT TURBINE FUEL	ALTERNATE FUEL
-40°F (-40°C) & ABOVE	MIL-T-83133	JP-8-AIRCRAFT TURBINE FUEL	ALTERNATE FUEL
+20°F (-7°C) & ABOVE	W-F-800	DF-2-DIESEL FUEL	ALTERNATE FUEL

# SECTION 3 - Preparation for Use & Storage

## 3.1 General

## 3.2 Scope

This heater is shipped as a pre-tested, completely assembled unit. Certain steps will need to be taken prior to putting the heater into operation or storage.

## 3.3 Preparation for use

To prepare the heater for use proceed as follows:

- (a) Remove all crating, blocking, and protective material from heater.
- (b) Check action of parking brake and set brake to prevent heater from rolling.
- (c) Inspect heater for any damage, loose connections or missing hardware.
- (d) Check V-belt for proper tension.
- (e) Fill tank with recommended fuel.
- (f) Fill and Check engine oil level.
- (g) Ensure tire pressure is 35 psi max.



Do not use forklift to move heater



### WARNING

Do not smoke or use an open flame in heater vicinity while servicing the fuel tank.

## 3.4 Preparation for Storage

To prepare heater for storage proceed as follow:

- (a) Drain fuel from tank
- (b) Replace fuel filter with a new filter.
- (c) Replace fuel nozzle.
- (d) Disconnect and remove battery.



### WARNING

Use protective clothing, face shield, rubber gloves and apron when removing battery from heater.



# SECTION 4 - Operation Instructions

---

## 4.1 General

### 4.2 Scope

This section describes the theory of operation, operating controls, indicators and the operation procedures for this heater.

### 4.3 Theory of Operation

The description will be presented in two parts; (1) General Description and (2) Detailed Description. The general description explains the interrelationship of functional components at an operational level. Functions of individual components and unique assemblies are given in the detailed description.

### 4.4 General Theory

Fuel is drawn from the tank through the filter and delivered under constant pressure to the variable discharge combustion nozzle (see figure 2-1). The temperature control valve opens and bypasses a metered amount of fuel back to the fuel tank. The ignition system produces a high voltage spark at the igniter plug to ignite the fuel and air mixture. The resultant flame heats the heat exchanger. Ambient air is forced through the heat exchanger by the fan assembly. As the ambient air passes through the heat exchanger it is directed through the heat deflector to the heat exchanger outlet.

As the heated air leaves the heat exchanger outlet, it passes over the thermostat sensing element. In the event of a high output temperature, there is an over temperature switch that detects this condition and turns off the burner.

### 4.5 Electrical System

A battery supplies power for the heater control circuits. A toggle switch on the control panel turns on the panel light for night time illumination. To start the diesel engine turn the ignition key to the START position and hold until engine starts then release ignition key. For cold-weather starting turn the ignition key to the PREHEAT position for one minute then turn key to the start position once engine is started move the key back to the PREHEAT position until the engine speed stabilizes then release the key. Power for the hour meter is provided from the burner switch thus being energized during burner operation to record the operating time. During engine operation a flywheel alternator produces a voltage which is maintained by the voltage regulator at a suitable potential for recharging of the battery. An emergency shut-off switch stops the burner and engine in case of an emergency A 12 volt power outlet is supplied for the accessories.

## SECTION 4

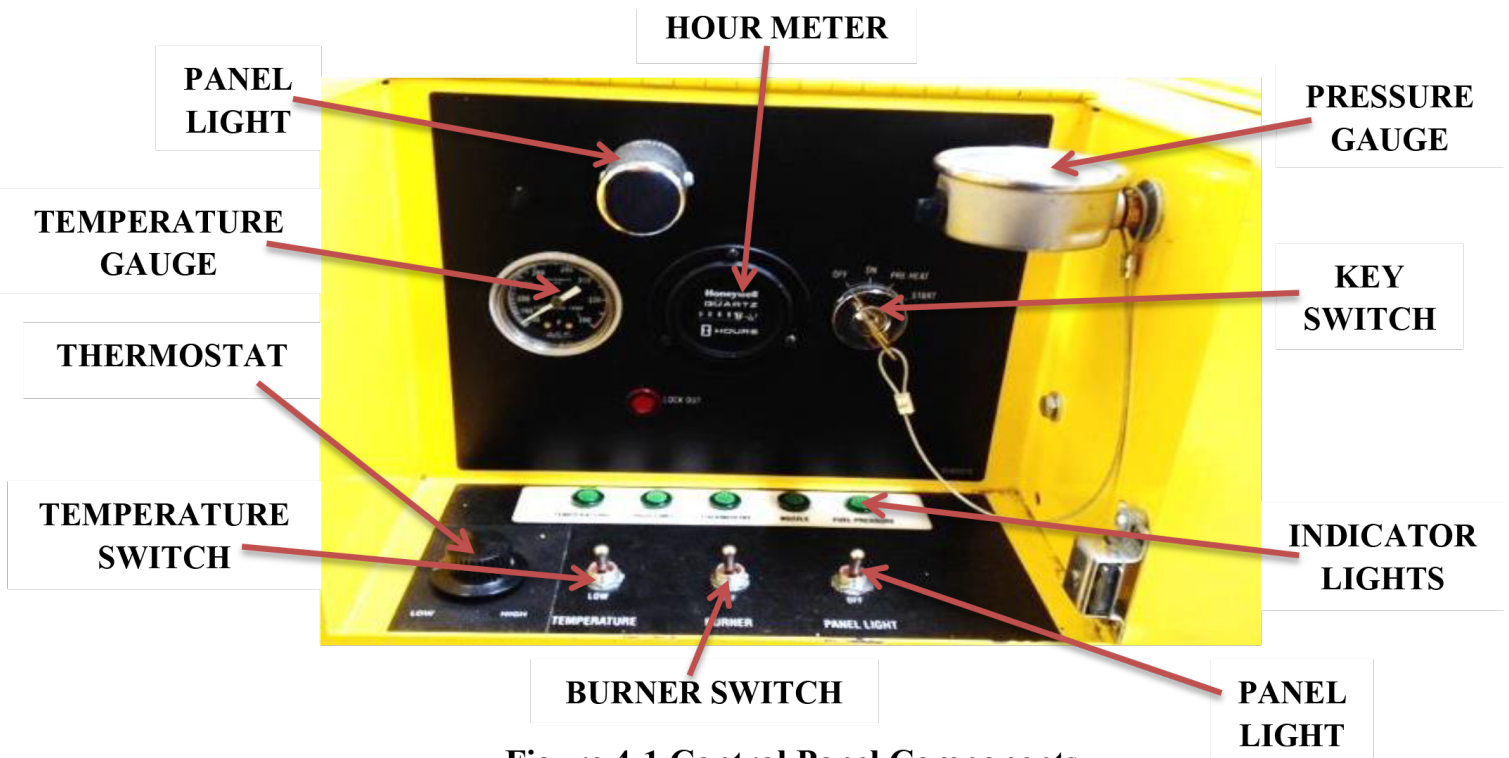

**Figure 4-1 Control Panel Components**

### 4.6 Detailed Theory

### 4.7 Fuel System

### 4.8 Fuel Pump

The fuel pump is mounted on a bracket to the left of the engine. The pump is belt driven by the diesel engine. There are three outlet ports and two inlet ports (see figure 4-2). A primary by-pass will handle all the flow if the balanced valve is closed. When the primary by-pass line is closed, the fuel will flow into the balanced valve and out through both the nozzle fuel line and the secondary by-pass line. Closing the burner valve, which is located in the primary by-pass line, allows the pump to build up pressure to the point where the valve opens allowing fuel flow in the nozzle fuel line. The pressure at which the balanced valve opens is determined by the compression of the piston spring, normally the spring is adjusted to 150 psi. The secondary by-pass supplies fuel to the engine and returns surplus back to the fuel tank. When the burner valve is open the pump cannot build up sufficient pressure to open the balanced valve and effect flow through the nozzle fuel line. Since the pump delivers fuel in excess of the maximum nozzle capacity maximum nozzle capacity there will always be flow through the secondary by- pass line when the burner valve is on. Fuel from the secondary by-pass flows back into the tank through a check valve which opens under a pressure of about 5 psi, this is sufficient to divert adequate fuel to the engine.

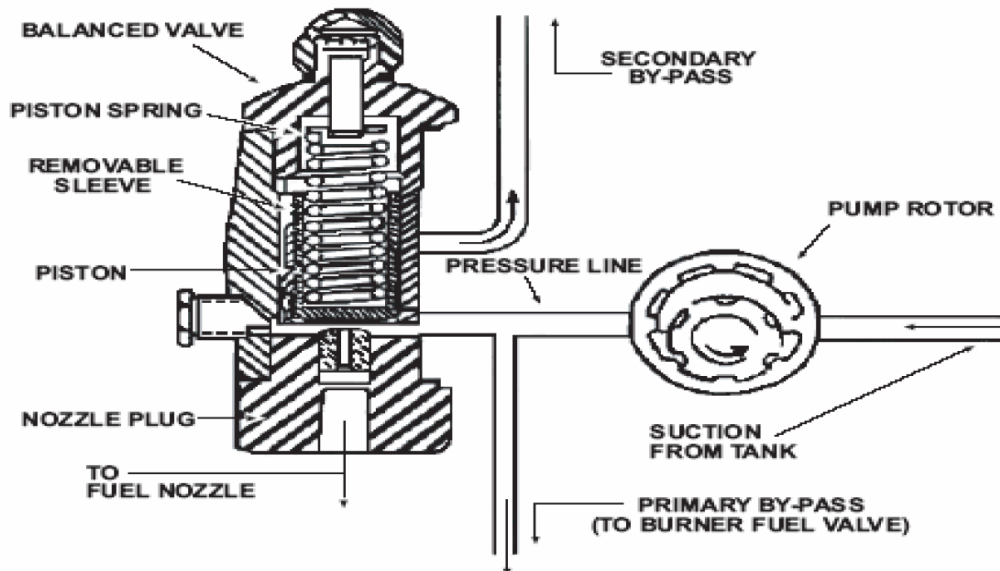

**Figure 4-2 • Schematic Diagram of Fuel Pump**

#### 4.9 Burner Control Valve

The burner control valve is a 12 volt DC electrically operated normally open valve that when energized closes, being located in the primary by-pass line this allows the pressure to build up in the balanced valve. This pressure opens the valve redirecting the fuel to the nozzle. The burner control valve also serves as an overheat protection safety valve in conjunction with a thermostat limit control disc. When the discharge air temperature exceeds safe limits (about 250°F), the thermostat snap disc limit control opens removing power from the valve. This turns off the burner. The valve will close again when the temperature drops below 230°F and the disc closes.

#### Fuel Atomizing Head

The fuel nozzle screws into a nozzle holder, the combination being known as the fuel atomizing head. Fuel from the inlet line enters the nozzle supply chamber through a strainer screen (see figure 4-4), then flows through slots in the inner head through which imparts a whirling motion to the fuel so that it partially atomizes as it enters the swirl chamber. Atomization is completed as the fuel sprays through the discharge orifice into the combustor. A portion of the fuel is also forced into a by-pass chamber which leads to the by-pass outlet passage in the nozzle holder. A check valve connected between the outlet and by-pass fuel line prevents a reverse fuel flow to the nozzle from the by-pass line. Fuel is discharged from the nozzle at a fixed continuous pressure and a continuous fixed flame is obtained. A change in heat output is obtained by varying the pressure of fuel discharged from the nozzle. This is accomplished indirectly by controlling the pressure of the fuel flowing through the by-pass fuel line through the action of the temperature selector valve.

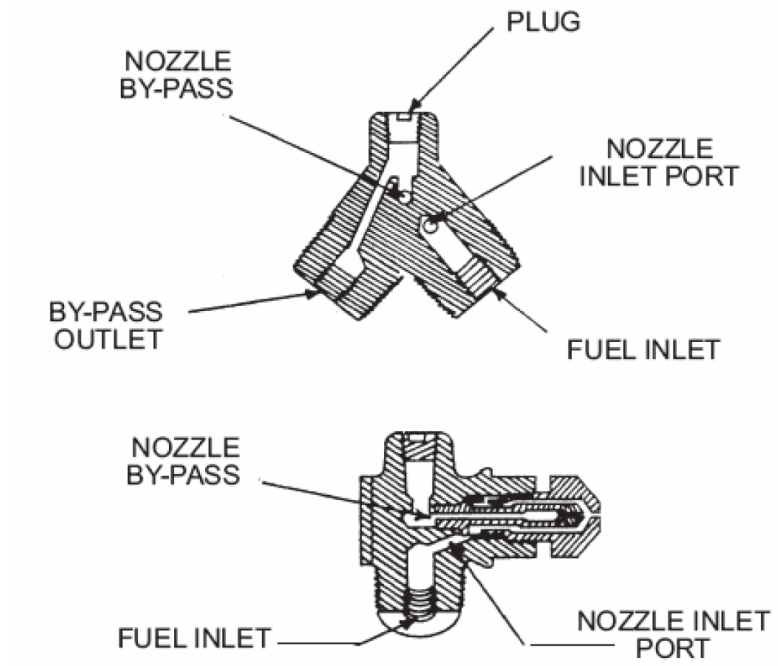

**Figure 4-4 • Fuel Atomizing Head**

#### 4.10 Temperature Control Valve

The temperature control valve is a 12 volt DC electrically operated normally open valve that when energized maintains a selected discharge temperature, from approximately 150°F to 250°F.

#### 4.11 Thermostat

The thermostat is a 12 volt DC electronic controller that supplies the voltage to the temperature control valve. The temperature range is from 150° F to 250°F. When a temperature is first selected 12 volts is sent to the temperature control valve. The valve closes and the pressure goes up to approximately 80psi or high flame. When the desired temperature is reached the voltage is removed from the temperature control valve and the pressure drops to approximately 25psi or low flame.

#### 4.12 Discharge Temperature Gauge

The discharge air temperature gauge is located in the control panel. This temperature gauge is a dial-type instrument which indicates the actual temperature (100°F to 350°F+/- 10°) of the discharge air in degrees Fahrenheit. A sensing element is mounted in the discharge air outlet.

#### 4.13 Emergency Shut-Off Switch

An emergency shut-off switch is located on the left side of the heater to the right of the access panel. This switch removes power from the burner control shutting off the burner and removes power from the time delay relay shutting off the engine.

#### 4.14 12 Volt Power Outlet

The 12 volt power outlet is located on the back of the rear hood. The power outlet supplies 12 volts for the strobe light.

**Figure 4-6 Heater Electrical System Circuit Diagram**

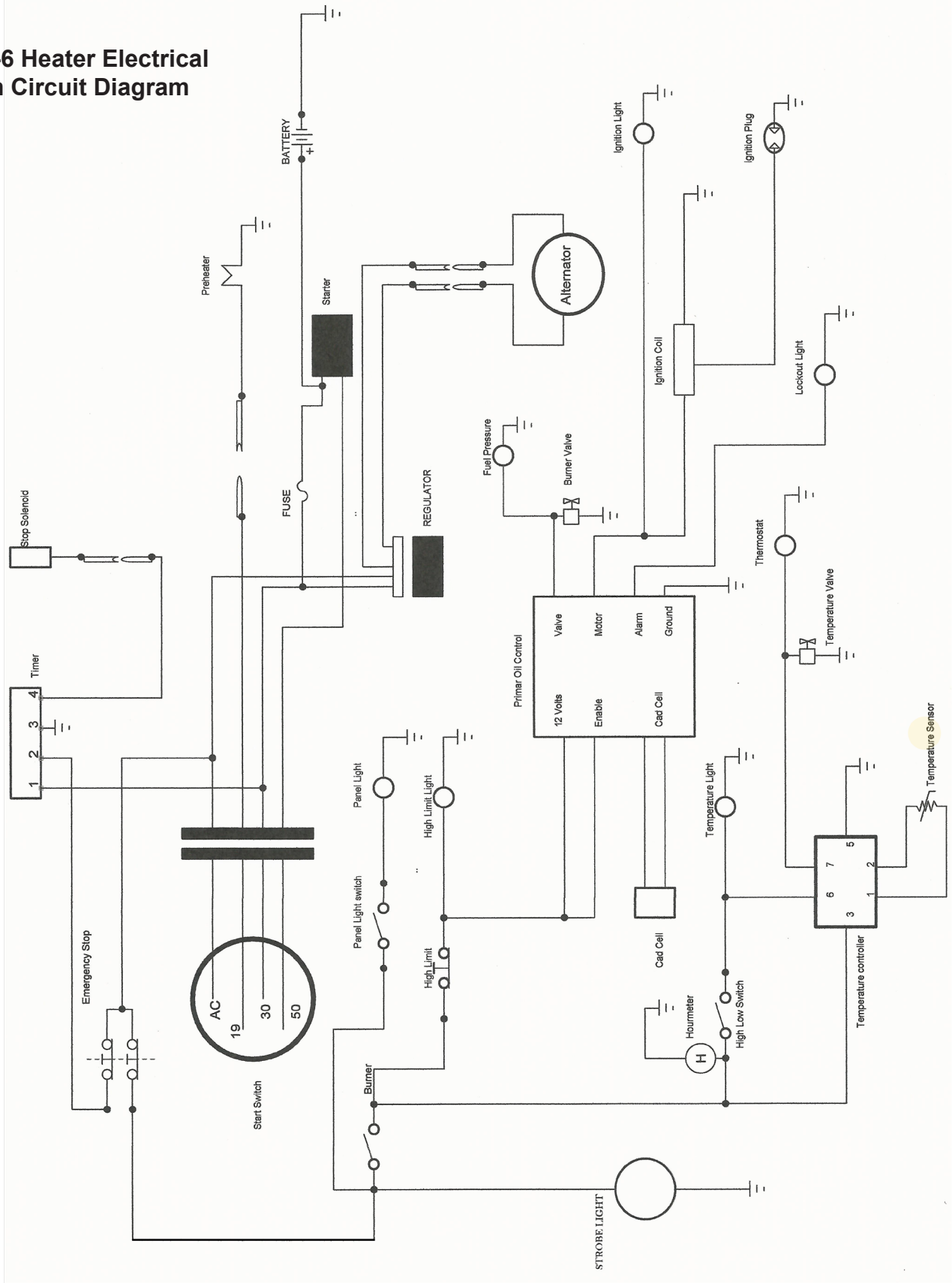

## SECTION 4

### 4.15 Electrical System

Refer to Figure 4-6 for the following description of the electrical system for this unit.

- a) A 12 VOLT battery supplies power for all control circuits. Battery negative corresponds to system electrical ground similar to most automotive systems.
- b) A toggle switch on the control panel turns on the panel light for nighttime illumination of controls on the panel.
- c) A key switch is moved to and held in the closed position to start the diesel engine.
- d) Closing the key provides a circuit to energize the starter solenoid. Its contacts close providing a circuit from the battery to the starter motor.
- e) For cold weather starting turn the key switch to (Preheat) and hold for about 1 minute then turn to the start position until the engine starts.
- f) Through the hour meter is energized to record total operating time.
- g) When closes battery power is provided to the ignition coil which provides a high voltage to produce a continuous arc across the gap to ignite the fuel.
- h) During engine operation the alternator produces a voltage which is maintained by the voltage regulator to recharge the battery.



### WARNING

The BT400-NEX-D heater is unsafe for operation in explosive atmosphere areas.

### 4.16 Operating Instructions

### 4.17 Preliminary Adjustments

Before starting the heater proceed as follows:



### WARNING

Exhaust gases from the combustion chamber and the diesel engine contain poisonous carbon monoxide gas. It is possible to contaminate the ventilating air with exhaust gases if these gases are drawn into the air inlet. The heater should be positioned so that the wind blows the exhaust gases away from the air inlet.

- (a) Tow trailer to site and select a location as close to level as possible. Out-of-level should not exceed 8 1/2 degrees.
- (b) Set parking brake.
- (c) Perform all inspection checks and services as listed in Section 5, Table 5-1.
- (d) Remove exhaust cover and place exhaust stack over exhaust pipe. If additional exhaust pipe is desired, use same size of pipe as used on the heater or larger. NEVER REDUCE PIPE SIZE. Limit length of exhaust pipe to 20 feet. Longer pipe runs may cause condensation of exhaust gases and other complications. All pipe joints must be tight. Pitch any connecting stack or pipe upward at least one foot of elevation for every ten feet of run.



## SECTION 4

(e) Remove air outlet cover and attach flexible ducts. A 12 inch flexible duct can be attached directly to the duct connector at air outlet. For 6 inch flexible ducts, install a 6 to 12 duct adaptor at the end of a 12 inch duct.



### WARNING

If heater is operated inside a building, the exhaust gases will be conducted to the outside by means of an extension pipe. Failure to comply may result in serious injury or death.



### NOTE

Kinks in the air ducts impede air flow. Spread out ducts to avoid sharp bends or kinks.

#### 4.18 Operating Under Normal Conditions

##### Start Up

- a) Check fuel level & Check engine oil level.
- b) Remove outlet and exhaust covers.
- c) Install exhaust stack and flexible air ducts.
- d) Open hood and insure that there is no fuel leaks and all is secure. Close hood.
- e) Open control panel access door. Ensure the burner switch is in the "OFF" position, temperature switch is in the "HIGH" position and that the thermostat selector is in the "LOW" position.
- f) Turn the engine start key to the "START" position and hold until engine starts then release.
- g) Allow the engine to run for about one minute or until the RPM has stabilized.
- h) For cold weather starting turn the key switch to "PREHEAT" and hold for about 1 minute then turn to the "START" position until the engine starts. Return to "PREHEAT" and hold until engine stabilizes then release.
- i) Turn burner switch to the "ON" position. Allow temperature to stabilize.
- j) "SLOWLY" turn the thermostat selector to the desired temperature.



### NOTE

New heaters and heaters with newly overhauled engines may require several seconds to start while air in the fuel lines is being purged.

##### Shut Down

- a) Turn the temperature selector down to "LOW" and leave the temperature switch in the "HIGH" position.
- b) Turn the burner switch to the "OFF" position and allow the temperature to cool down.
- c) Once the temperature is in the green turn the key to the "OFF" position.
- d) Remove the exhaust stack and ducts from heater. Store away as necessary.
- e) Install the outlet and exhaust covers.
- f) In case of emergency press the red emergency shut off to shut down unit.

## Maintenance Instructions

### 5.1 General

### 5.2 Scope

This section contains instructions for maintaining BT400-NEX-D. If performed on a regular basis will insure proper operation and extended life of the heater.

### 5.3 Cleaning

For access to the heater components for cleaning, proceed as follows:

(a) Open hood.



### WARNING

Compressed air used for cleaning will not exceed 30 psi and then only with approved personnel protective equipment such as safety goggles or face shield.

(b) Brush dirt and dust from the components with a soft bristle brush. Blow dirt and dust away using dry compressed air.

(c) Remove corrosion from battery posts and cable clamps using a battery brush. Clean battery with a weak solution of baking soda and warm water. Rinse with clean water. Clean battery tray in the same manner.

(d) With hood and access doors closed tightly, wash heater using a scrub brush to apply a solution of detergent in warm water. Remove the detergent solution with clean water.

### 5.4 Flexible Ducts

Wash ducts with soap or detergent and water. Dry with a soft cloth. Ensure ducts are thoroughly dry before putting duct away.

### 5.5 Inspection and Preventive Maintenance

Preventive maintenance checks, services, and inspections are listed in table 5.1. Checks, services and inspections should be accomplished at time intervals listed in the interval column.



### WARNING

Never perform any maintenance until the heater has been allowed to cool and the battery has been disconnected

Table 5-1 Inspection checks

COMPONENT	INSPECTION, CHECK OR SERVICE	INTERVAL
Heater unit	Visually inspect for loose, missing or damaged hardware.	Daily
Air ducts	Visually inspect for damage or wear. Replace as necessary.	Daily
Engine	Check oil level, add oil if necessary.	Daily
Engine Air Filter	Check for dirt. Clean if necessary.	Daily
Tires	Check for abnormal or uneven wear, cuts and embedded foreign material. Check for proper air pressure.	Daily
Controls and Instruments	Visually inspect for damage. Replace if necessary.	Daily
Fuel Gauge	Visually inspect for damage. Replace if necessary.	Daily
Exhaust system	Inspect for secure mounting, cracks or dents. Inspect exhaust stack and extensions for damage. Check screen for damage. Clean or replace as necessary.	Weekly
Fuel System	Inspect all lines for kinks, breaks, and loose connections. Tighten or replace as required.	Weekly
Fan, Mounting Ring and Pulley	Inspect for security, cracks, or other damage. Check for vibration during operation. Inspect flexible rubber sleeve for cracks, broken teeth or deterioration. Repair or replace defective parts.	Monthly
V-belt	Check for proper adjustment. Inspect for wear, fraying and stretching. Replace if necessary. ( para: 5:10)	Monthly
Engine	Change oil.	Yearly
Fuel Filter	Replace Filter	3 Months
Fuel Pump	Check pump for proper operation. (para: 5.27)	Yearly
Ignition System	Check system for loose or bad connections, broken insulators, kinks, or breaks in shielding. Check point gap.	6 Months
Heat Exchanger	Inspect for carbon deposits or other defects. Clean or replace as necessary.	Yearly
Ventilating Air	Perform carbon monoxide test. (para: 5.20)	Yearly

## SECTION 5

### 5.6 Battery



## WARNING

Use protective clothing, face shield, rubber gloves and apron when removing battery

### 5.7 Battery Removal

To remove battery, proceed as follows:

- (a) Gain access to battery.
- (b) Disconnect battery cables from battery. Remove negative cable first.
- (c) Remove battery hold down bracket.
- (d) Remove battery.

### 5.8 Battery Installation

To install battery, reverse removal procedures.

### 5.9 Fuel Filter

The fuel filter element is non-reusable. Replace fuel filter as follows:

- (a) Gain access to fuel filter assembly.
- (b) Remove bolt from top of fuel filter assembly.
- (c) Remove base and gasket.
- (d) Remove element from base.
- (e) Install new element and gasket.
- (f) Install bolt securely to base through top assembly.

### 5.10 V-Belt

The v-belt encircles the driven coupling and fuel pump.

#### V-Belt Adjustment

To adjust the v-belt, proceed as follows:

- (a) Open hood.
- (b) Loosen the two bolts securing the fuel pump to the fuel pump mounting bracket.
- (c) Move the fuel pump to the left to tighten the v-belt. To check the tension, depress the v-belt between the driven coupling and the fuel pump. The deflection should be 1/2 inch with 5 pound of force.

## SECTION 5

### 5.11 Heat Exchanger Assembly

### 5.12 Heat Exchanger Assembly Removal

To remove the heat exchanger assembly, proceed as follows:

- (a) Remove hood assembly by removing the 8 bolts and washers that secure hood to heater. Remove capillary tube cover. Lift hood from heater.
- (b) Remove the 4 bolts from mounting brackets of heat exchanger assembly.
- (c) Remove clamps from flexible exhaust hose and remove hose.
- (d) Remove V-belt by slipping belt from pulleys.
- (e) Remove duct adapter at rear of heat exchanger assembly. Remove sensing elements.
- (f) Remove heat exchanger assembly from trailer assembly.

### 5.13 Heat Exchanger Assembly Installation

To install heat exchanger assembly, proceed as follows:

- (a) Place heat exchanger on trailer assembly and align with engine. Using shims under heat exchanger mounting brackets may be required to obtain proper alignment. Maximum parallel misalignment is 0.015 inches. Maximum angular misalignment is 0.056 inches.
- (b) Tighten the 4 mounting bolts.
- (c) Install sensing element in discharge air stream and install duct adapter.
- (d) Install V-belt. Ensure proper belt tension.
- (e) Install capillary tube cover.

### 5.14 Fan and Mounting Ring Assembly

The fan delivers all the air necessary for the operation of the heater. Power for the fan is transmitted by a flexible rubber coupling which mate with the drive coupling on the engine and a driven coupling which is pressed onto the fan shaft. A cast steel mounting ring supports the fan and associated parts.

### 5.15 Fan and Mounting Ring Removal

To remove fan and mounting ring assembly, proceed as follows:

- (a) Remove heat exchanger assembly following procedures listed in paragraph 5.25.
- (b) Remove the 3 bolts securing mounting ring to casing and remove ring.

### 5.16 Fan and Mounting Ring Installation

To install the fan and mounting ring assembly, reverse the removal procedures.

## SECTION 5

### 5.17 Heat Exchanger

### 5.18 Heat Exchanger Disassemble

To remove the heat exchanger, proceed as follows:

- (a) Remove heat exchanger assembly.
- (b) Remove fan and mounting ring assembly.
- (c) Disengage clamp from notches in combustion chamber. Remove nozzle holder and combustor plate.
- (d) Remove fuel lines from nozzle holder.
- (e) Remove ignition cable from igniter plug.
- (f) Remove exhaust stack and cover by removing the 12 screws and washers.

Remove gasket.

- (g) Remove heat exchanger from heat exchanger housing by pulling the heat exchanger from the front of housing.

### 5.19 Heat Exchanger Reassemble

To assemble the heat exchanger, reverse the disassemble procedures.

### 5.20 Carbon Monoxide Test

To check the heaters' ventilating air stream for carbon monoxide contamination, proceed as follows:

 **NOTE**

On heaters that are used on a seasonal basis, this test shall be performed prior to the heater being put into service. Additional tests shall be performed any time contamination is suspected or if maintenance has been performed on exhaust system.

- (a) Attach one 12 inch by 15 feet duct to heater. Attach a 3 way 12" to 6" duct adapter to the 12 inch duct and attach three 6 inch by 15 feet duct to adapter. Ensure there are no kinks in the ducts.
- (b) Start heater using proper start procedures. Rotate thermostat selector "SLOWLY" to obtain a discharge temperature of 200°F.
- (c) Using a carbon monoxide tester, measure the carbon monoxide level at one of the six inch ducts. The carbon monoxide level will not exceed 35 PPM.

### 5.21 Heater Ignition System

Components of the ignition system are the coil, ignition cable and the igniter plug.

### 5.22 Coil

The coil is mounted on top of the heat exchanger in the engine compartment.



## SECTION 5

### 5.23 Ignition Cable and Igniter Plug

### 5.24 Ignition Cable and Igniter Plug Removal

To remove ignition cable and igniter plug, proceed as follows:

- (a) Remove fan mounting ring.
- (b) Disconnect the ignition cable from igniter plug and coil.
- (c) Remove grommet from casing and remove ignition cable.
- (d) Remove igniter plug from combustion plate.
- (e) Disengage clamp from notches in combustion chamber and remove combustion plate.
- (f) Clean igniter plug and ignition cable and inspect for cracks, burning, pitting or other damage. Replace as necessary.

### 5.25 Ignition Cable and Igniter Plug Installation

To install ignition cable and igniter plug, proceed as follows:

- (a) Install the igniter plug in the combustion plate. Measure the point gap. The gap should be 0.125 inch to 0.1875 inch (1/8 to 3/16). Bend the electrode to obtain correct gap.



CAUTION

Do not bend the igniter plug electrode



- (b) Install combustion plate on combustion chamber.
- (c) Insert nozzle holder, with clamp in notches on combustion chamber.
- (d) Insert ignition cable to igniter plug and coil.
- (e) Install fan and mounting ring.



ELECTRODE

**Figure 5-1 Igniter Plug Adjustment Point**

## SECTION 5

### 5.26 Fuel Pump

The fuel pump is mounted on a bracket installed next to the fuel filter. The pump is belt driven by the engine.

### 5.27 Fuel Pump Adjustment

Pressure testing and adjustment of the fuel pump should be performed as follows:

- (a) Start engine and allow it to warm up. During warm up, observe pressure gauge. The reading should be about 20 psi. Engage burner and ensure fuel has ignited. Pressure gauge should read 140 psi to 150 psi.
- (b) If pressure is not within tolerance, adjust pump by removing the end cap nut on top of pump and turning adjusting screw. Rotate screw clockwise to increase and counter clockwise to decrease pressure.

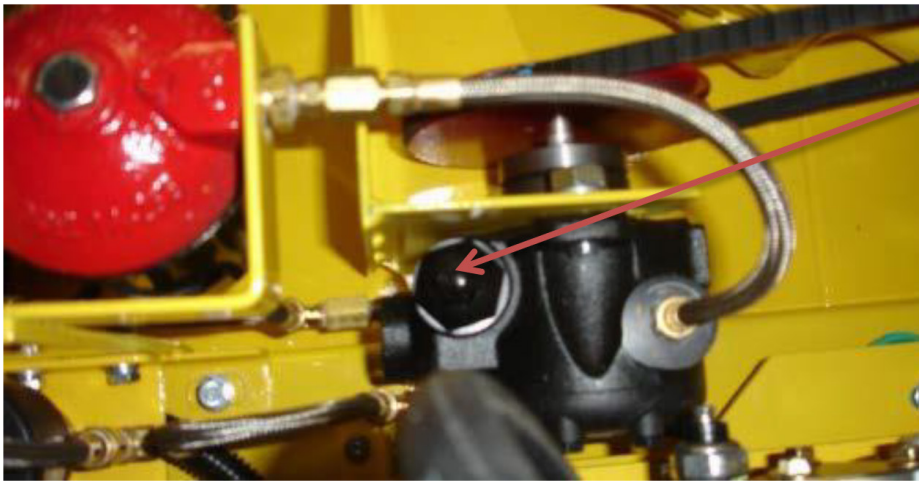

**PRESSURE  
ADJUSTMENT**

**Figure 5-2 Fuel Pump**

### 5.28 Fuel Pump Removal

To remove the fuel pump, proceed as follows:

- (a) Remove the v-belt by slipping it off the fuel pump pulley.
- (b) Remove the fuel lines on the pump.
- (c) Remove the pulley by loosening the set screw.
- (d) Remove the mounting two bolts from the fuel pump and remove the pump.

### 5.29 Fuel Pump Installation

To install the fuel pump, reverse the removal procedures.



**NOTE**

Check belt tension after installing the fuel pump.

# SECTION 5

## 5.30 Troubleshooting

The troubleshooting chart (Table 5-3) list the possible cause and correction action to be taken, as listed in sequence of possible occurrence. The troubleshooting procedures assume all operating controls are properly set adjusted for the selected mode of operation.

Table 5-3 Troubleshooting Chart

	PROBLEM	POSSIBLE CAUSE	CORRECTIVE ACTION
1	Engine will not start	1. Battery cables loose or not connected	Connect battery cables or tighten
		2. Insufficient fuel supply.	Fill tank with appropriate fuel.
		3. Dead battery	Charge or replace battery
2	Engine turns over but fails to start or starts then stops	1. Insufficient fuel supply.	Fill tank with appropriate fuel.
		2. Clogged filter.	Replace filter.
		3. Fuel return check valve dirty.	Clean or replace check valve.
		4. Faulty fuel pump.	Check fuel pump
		5. V-belt slipping	Adjust v-belt.
		6. Engine fault	Refer to engine supplement
3	Engine stops suddenly	1. Insufficient fuel supply.	Fill fuel tank with appropriate fuel
		2. Contaminated fuel.	Drain and flush tank. Refill and replace fuel filter
		3. Incorrect fuel supply	Drain and flush tank. Fill with appropriate fuel.
4	Burner fails to ignite	1. Insufficient fuel supply.	Refer to trouble 2
		2. Defective fuel pump.	Check fuel pump or replace
		3. Fuel pump pulley slipping	Tighten set screw on pulley.
		4. Defective burner valve.	Replace burner valve.
		5. Defective coil	Replace with serviceable coil.
		6. Defective ignition cable.	Replace cable.
		7. Defective igniter plug.	Adjust igniter plug or replace.
		8. Emergency Shut-Off Switch in.	Pull out switch
5	Burner ignites by itself	1. Defective burner control valve	Clean or replace burner control valve
		2. Defective control box	Replace control box
6	Excessive smoke emitted from exhaust	1. Air flow restricted	Remove restriction
		2. Engine operating below normal speed.	Check engine speed
		3. Incorrect nozzle spray pattern	Clean or replace nozzle
		4. Carbon buildup in exhaust system	Clean exhaust system
		5. Excessive fuel pressure.	Adjust pump pressure

Table 5-3 Troubleshooting Chart

	TROUBLE	PROBABLE CAUSE	REMEDY
7	Combustor flame cuts out	1. Insufficient air supply	Remove restriction.
		2. Discharge air restricted	Remove restriction
		3. Defective high limit switch	Replace high limit switch
8	Combustor flame fails to go out or unit overheats	1. Defective burner valve	Replace valve.
		2. Defective high limit switch	Replace high limit switch
		3. Defective burner switch	Replace switch
		4. Control set point to high	Adjust the control set point
		5. Sensor shorted	Replace sensor
9	Maximum heat output not obtainable	1. Fuel system leak.	Inspect fuel lines, tighten loose connections. Replace damaged fuel lines.
		2. Defective fuel pump.	Check pump or replace
		3. Clogged fuel filter	Inspect and replace filter.
		4. Defective temperature control valve.	Replace valve.
		5. Heat exchanger clogged.	Clean heat exchanger.
10	After burning in combustion chamber	1. Nozzle check valve being held open by contaminant.	Clean or replace valve.
		2. Defective nozzle.	Clean or replace nozzle.
		3. Fuel leak in nozzle holder or fuel lines at nozzle holder.	Tighten or replace fuel lines.
11	No temperature control or heater will not go into high flame	1. Thermostat not wired correctly	Wire as per wiring diagram
		2. Control set point too low	Adjust control set point
		3. Open sensor	Replace sensor
		4. Control power is incorrect	Check battery voltage
		5. Defective temperature valve	Replace valve

Parts List

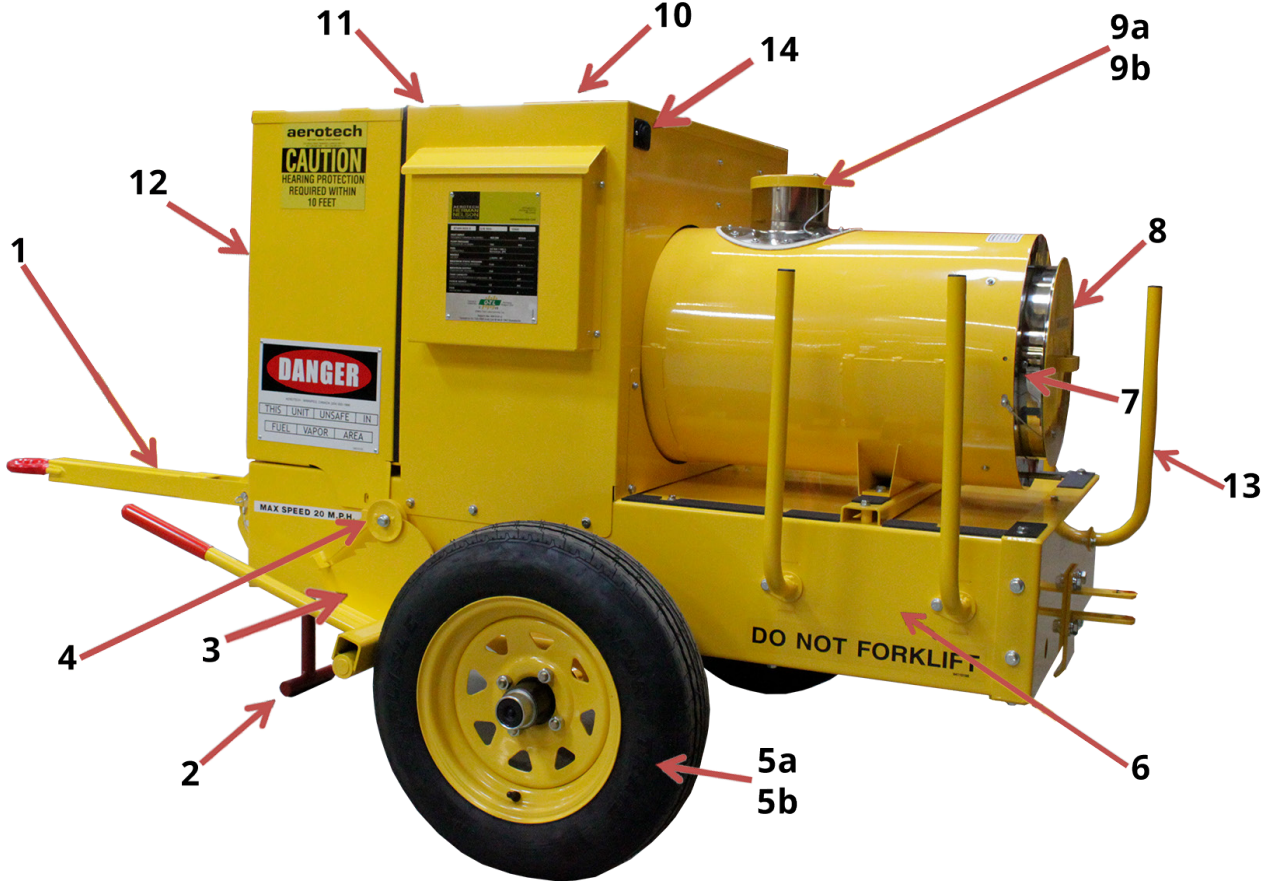

Figure 6-1 Heater

Item	Part Number	Description	Quantity
1	8130292-10-OK	LONG TOW BAR	1
2	8227188-10	KICKSTAND	1
3	ADH-0040W	BRAKE ASSEMBLY	1
4	ADH-0081W	BRAKE LOCK	1
5a	ADH-0010A	AXLE ASSEMBLY	1
5b	05300990	TIRE	2
6	ADH-0082W	TRAILER MAIN FRAME	1
7	04040020	DUCT ADAPTER	1
8	04040011	OUTLET COVER	1
9a	04040014	SPARK ARRESTOR	1
9b	TR3313	EXHAUST STACK COVER	1
10	05000123MODA	RUBBER STOPPER	2
11	ADH-0018W	HOOD, REAR	1
12	ADH-0023A	HOOD, FORWARD	1
13	AGH-0004W	DUCT HANGER	6
14	05300651	12V POWER SOCKET	1



# SECTION 6

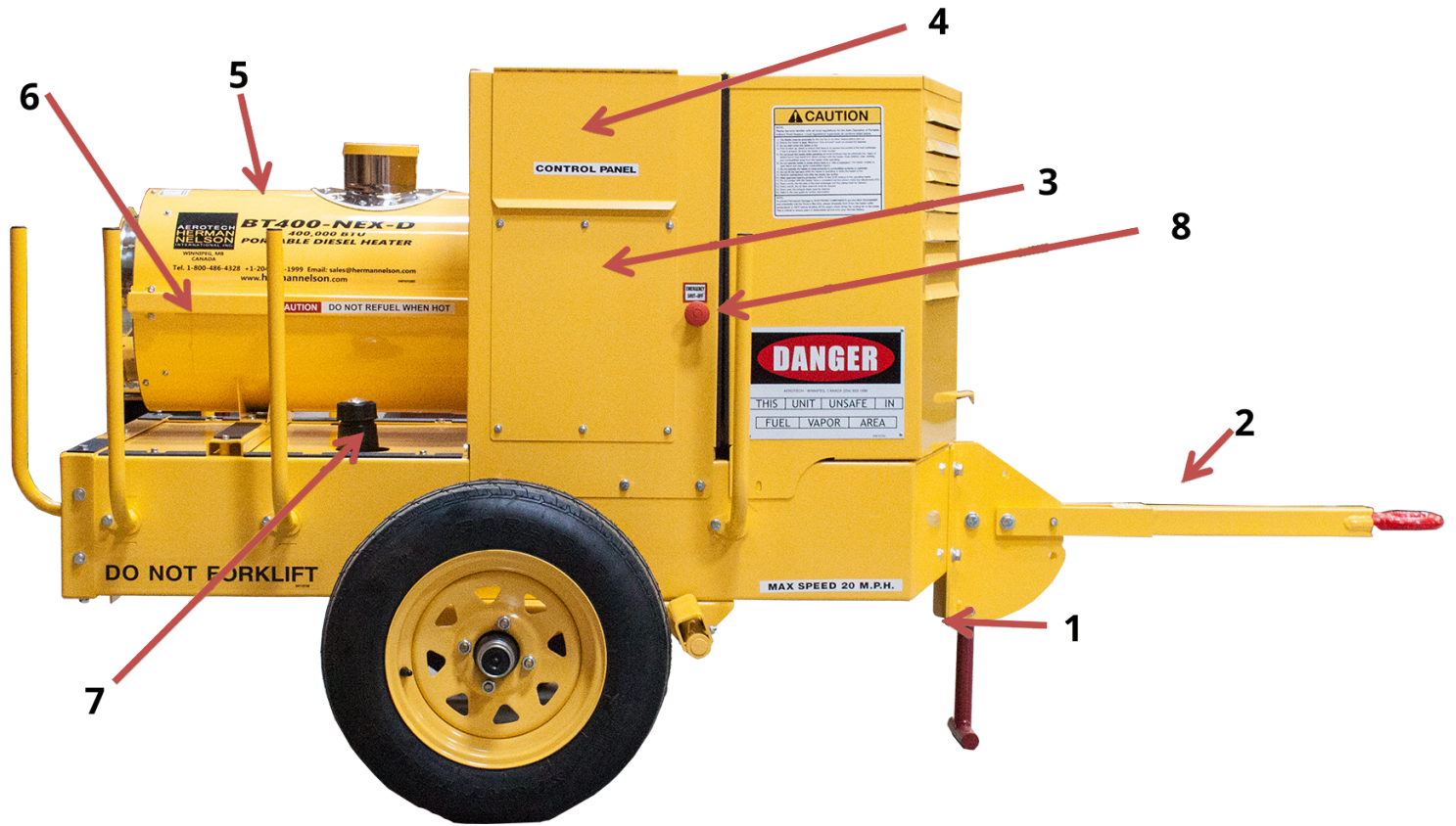

Figure 6-2 Heater

Item	Part Number	Description	Quantity
1	8227188-10	KICK-STAND	1
2	8130292-10-OK	TOW BAR	1
3	05000136-OK	REAR HOOD SERVICE PLATE	1
4	05310224	ACCESS DOOR	1
5	04050032AT-OK	HEAT EXCHANGER CASING	1
6	04100183	CAPILLARY SHIELD	1
7	05300104	FUEL TANK (POLY)	1
8	05300652	EMERGENCY SHUT-OFF STOP SWITCH	1



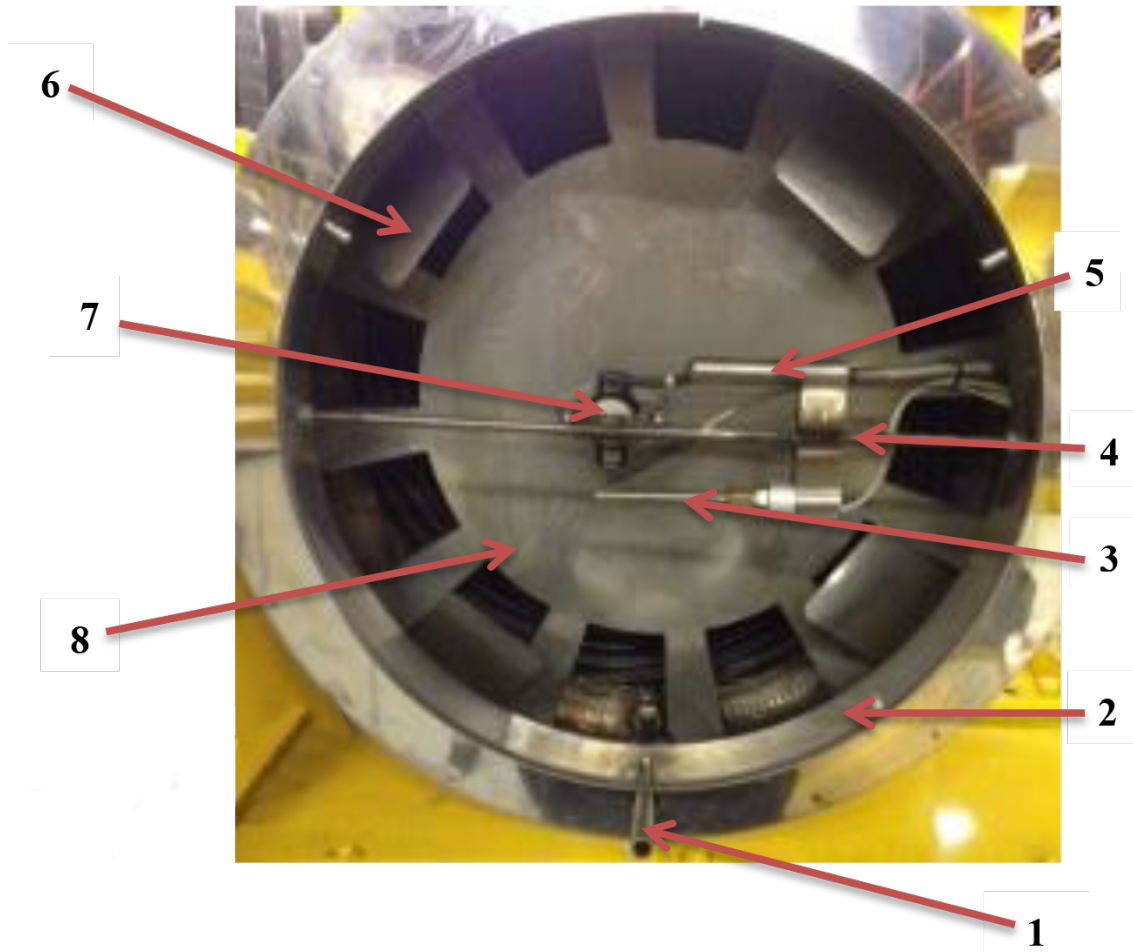

Figure 6-3 Heater Outlet

Item	Part Number	Description	Quantity
1	TRF3094	DRAIN TUBE	1
2	04040020	DUCT ADAPTER	1
3	05300360	THERMOSTAT PROBE	1
4	TAF3157MODD	SUPPORT BULB & COIL	1
5	TR3276	DISCHARGE TEMPERATURE GAUGE PROBE END	1
6	TA235	HEAT CONTROL BAFFLES	4
7	05300085	HIGH TEMPERATURE SWITCH	1
8	TAF3154-MODA	RADIATION SHIELD	1

# SECTION 6

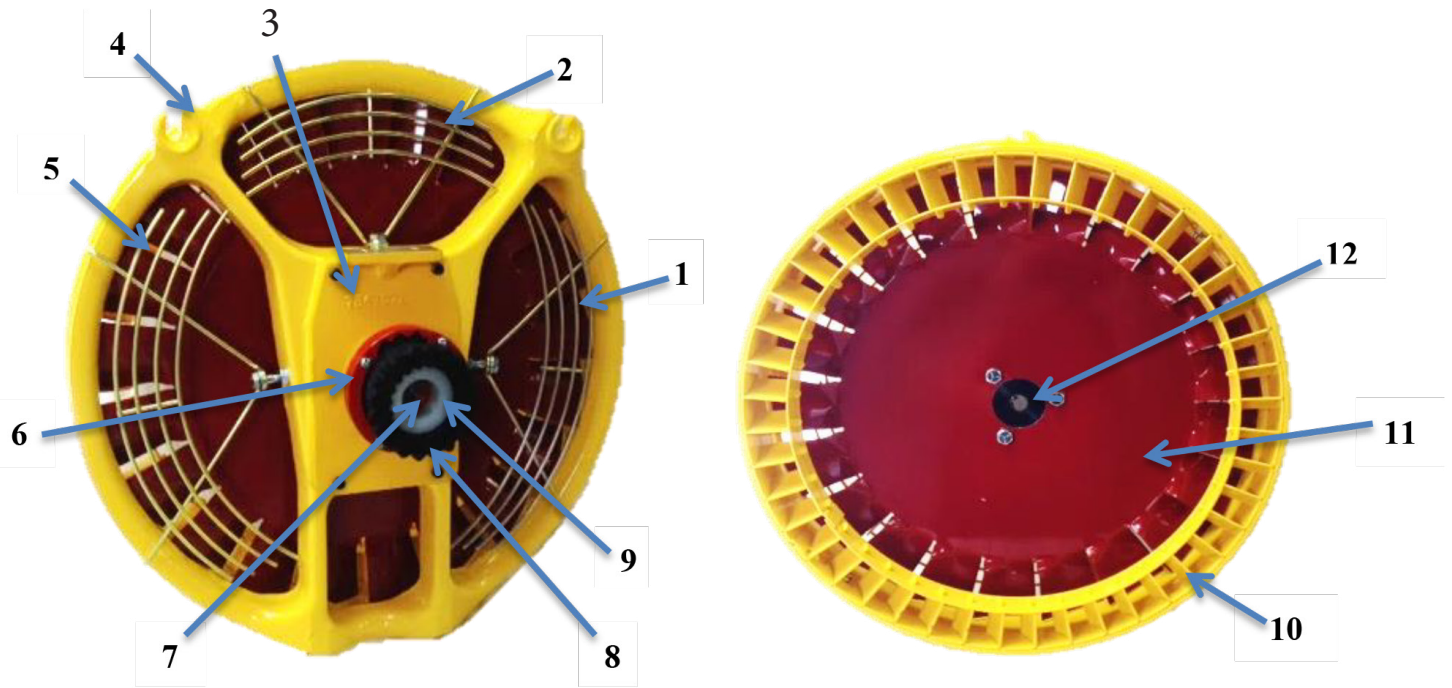

Figure 6-4 Fan Assembly

Item	Part Number	Description	Quantity
1	04020173	FAN GUARD (RIGHT)	1
2	TMF106	FAN GUARD (TOP)	1
3	04030002	BEARING SUPPORT	1
4	04010017	FAN RING	1
5	04020174	FAN GUARD (LEFT)	1
6	TM3917-1	DRIVEN COUPLING	1
7	TM3916	BEARING SHAFT	1
8	TM3917-2	SLEEVE COUPLING (RUBBER)	1
9	TM3927	SLEEVE BUSHING (NYLON)	1
10	04040022	AIR STRAIGHTENING VANE	1
11	04040018	FAN	1
12	TM3921	FAN HUB	1

# SECTION 6

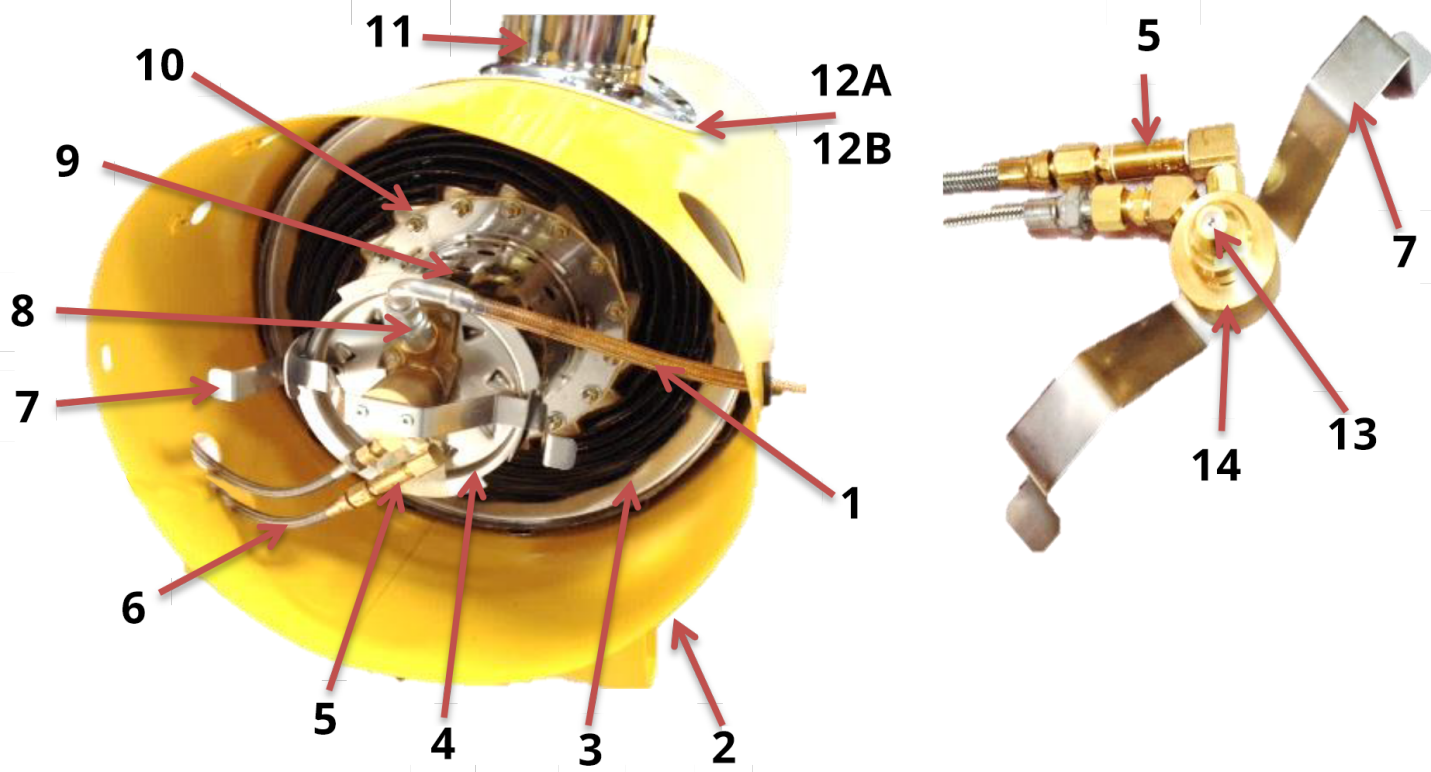

Figure 6-5 Heat Exchanger Assembly

Item	Part Number	Description	Quantity
1	04100156	IGNITION CABLE	1
2	04050032AT-OK	HEAT EXCHANGER CASING	1
3	8227028-10	HEAT EXCHANGER	1
4	TRF762 MOD A	COMBUSTOR PLATE	1
5	T0655A	5 PSI CHECK VALVE	1
6	04100157-1	FUEL LINE	2
7	T0553C	COMBUSTOR NOZZLE CLAMP	1
8	TE1010B	IGNITER PLUG	1
9	04040008	COMBUSTOR W/PIPE	1
10	TR776A	COMBUSTOR GASKET	1
11	04040015	EXHAUST STACK (No Hole)	1
12a	TX595	HEAT EXCHANGER GASKET	1
12b	TX592	EXHAUST STACK GASKET	1
13	TR778	FUEL NOZZLE 2.0 GPH	1
14	05300144	NOZZLE HOLDER	1



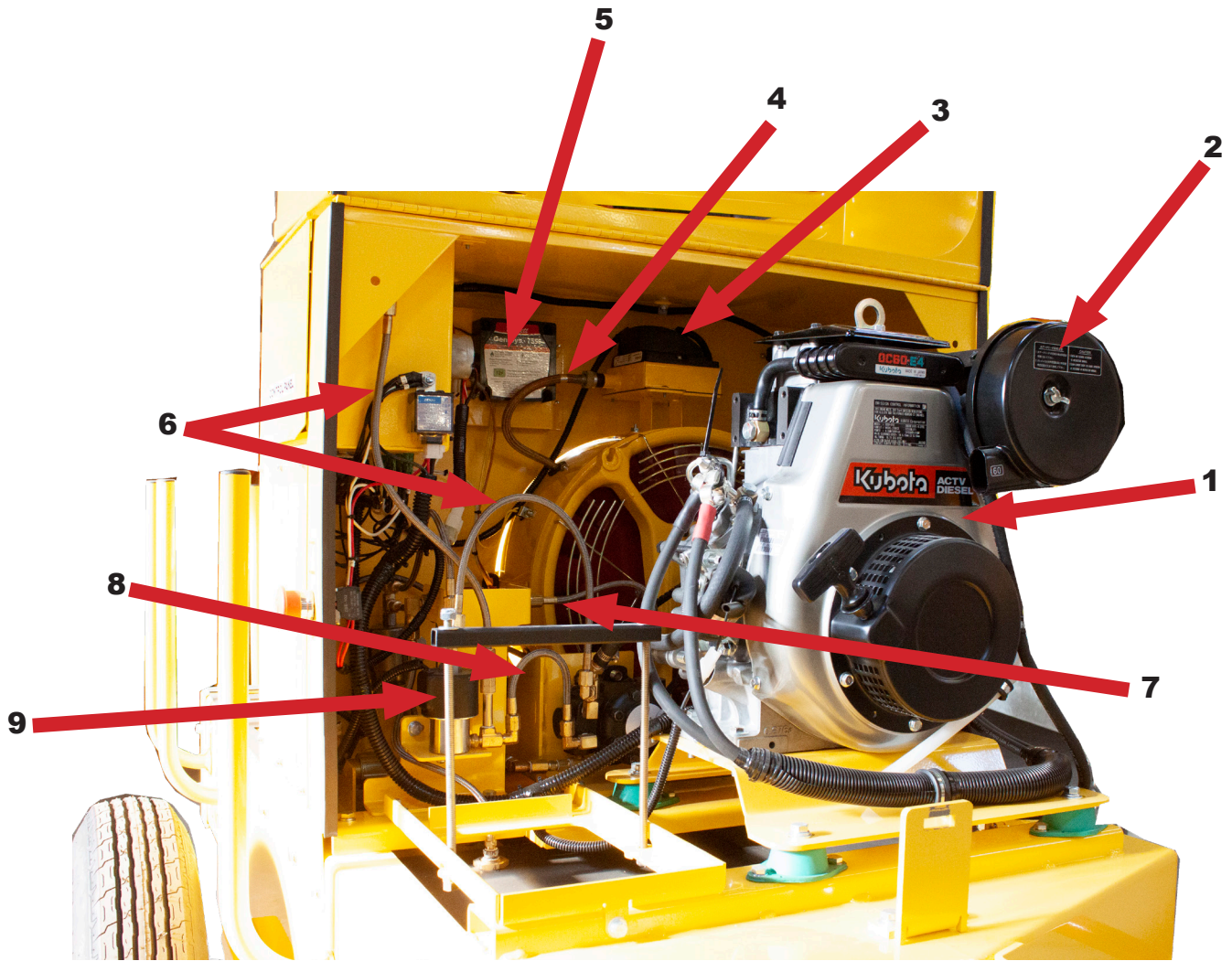

Figure 6-6 Heater Engine Compartment

Item	Part Number	Description	Quantity
1	OC60D1QX3	KUBOTA ENGINE	1
2	11520-12050MM	MODIFIED MUFFLER	1
3	04100113	IGNITION COIL	1
4	04100156	IGNITION CABLE	1
5	05300050	BURNER CONTROL	1
6	05300410	16 INCH FUEL LINE	3
7	05300405	10 INCH FUEL LINE	1
8	05300400	8 INCH FUEL LINE	1
9	05300255	BURNER FUEL VALVE	1

# SECTION 6

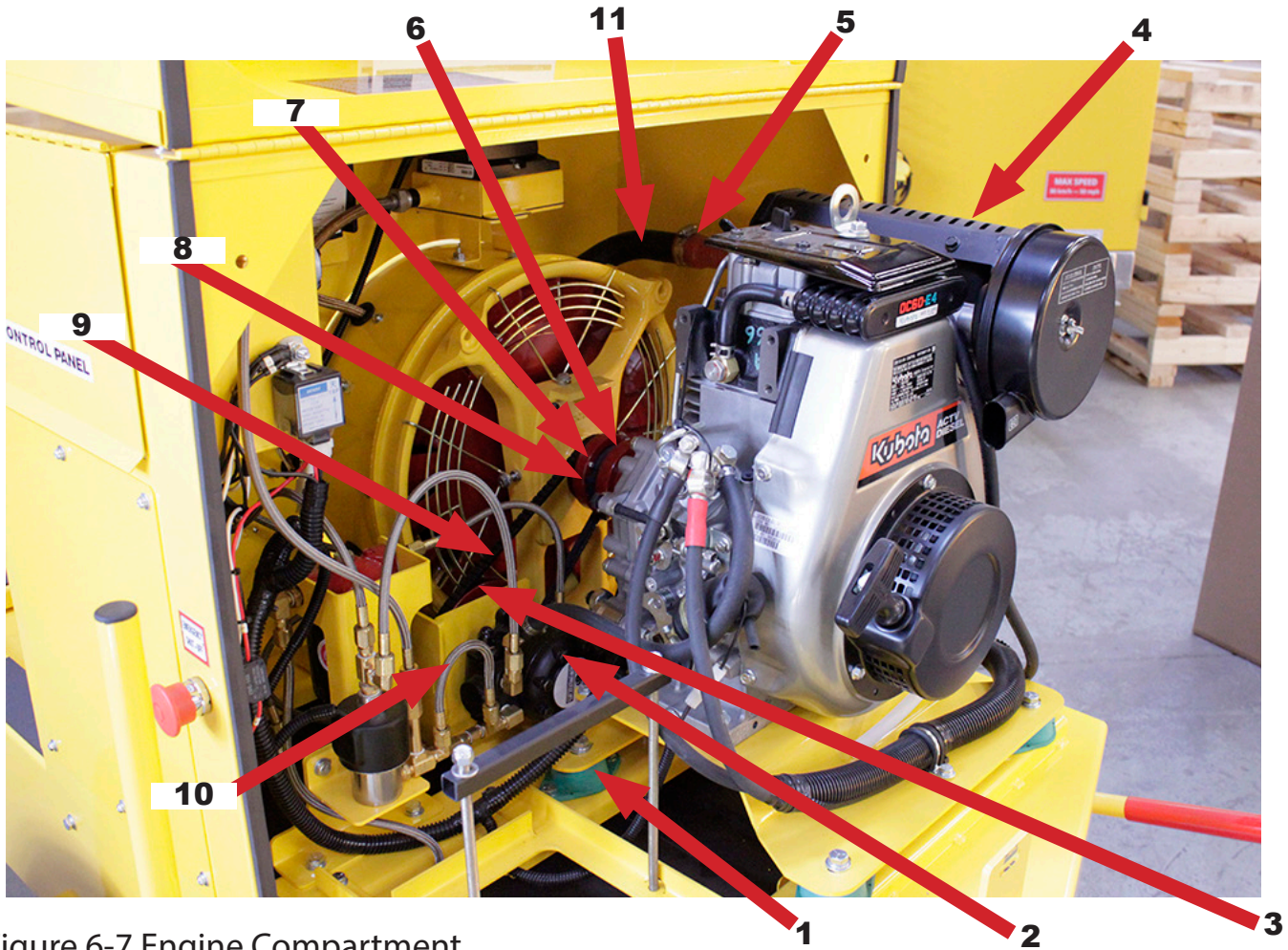

Figure 6-7 Engine Compartment

Item	Part Number	Description	Quantity
1	05300141	MOTOR MOUNT	4
2	TR3277	FUEL PUMP	1
3	TM3919	PULLEY, FUEL PUMP	1
4	11520-12050MM	MODIFIED MUFFLER	1
5	04100155	FLEX EXHAUST HOSE	1
6	TM3917-3	DRIVE COUPLING	1
7	TM3917-2	SLEEVE COUPLING (RUBBER)	1
8	TM3917-1	DRIVEN COUPLING	1
9	MS15290	FAN-BELT	1
10	05300400	8 INCH FUEL LINE	1
11	04100154	EXHAUST PIPE COMBUSTOR	1



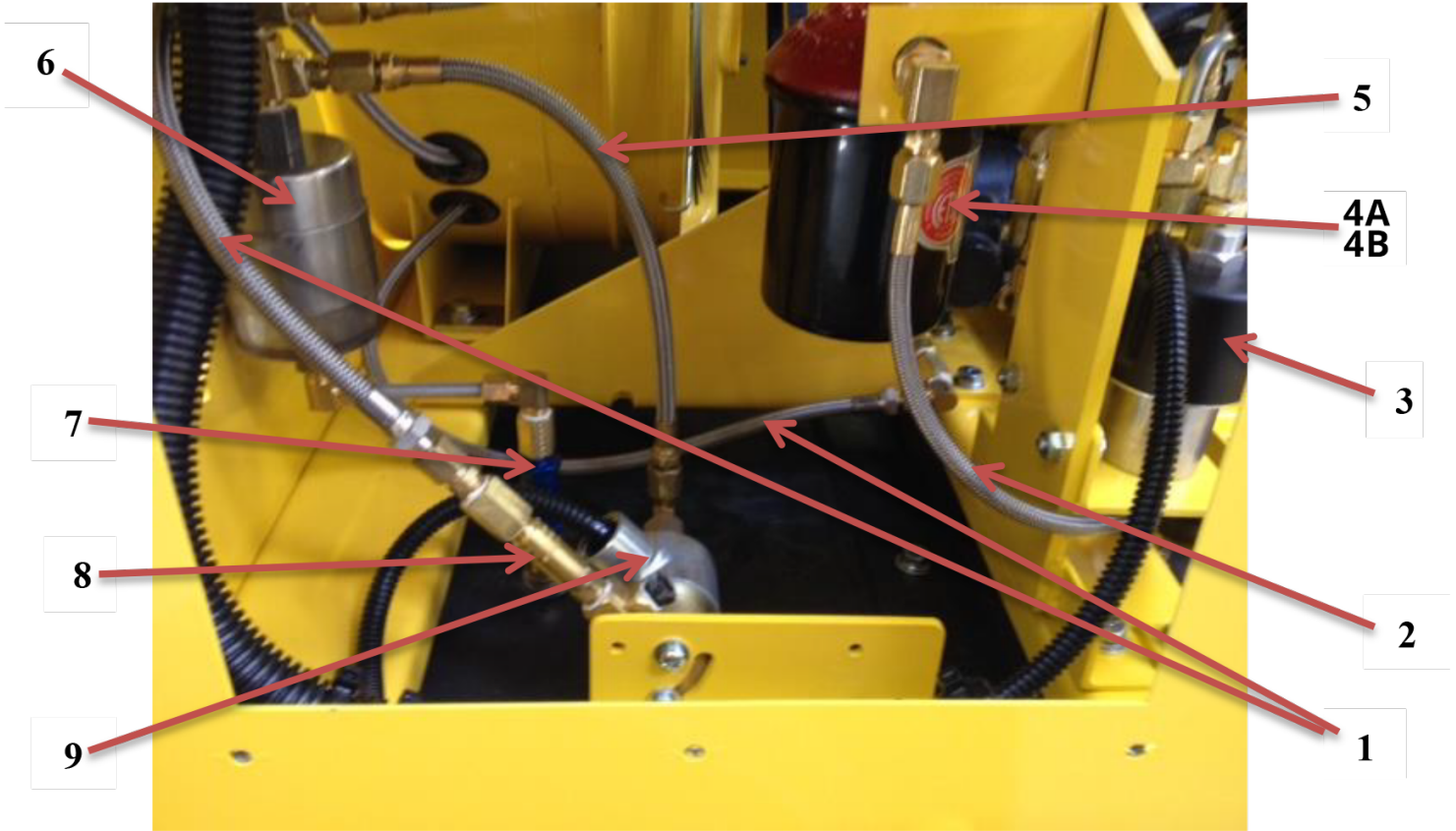

Figure 6-8 Valves and Filters

Item	Part Number	Description	Quantity
1	04100157-1	FUEL LINE	2
2	T0631	FUEL LINE	1
3	05300255	BURNER FUEL VALVE	1
4A	1A-25A	FUEL FILTER ASSY	1
4B	1A-30	FUEL FILTER ELEMENT (INSIDE)	1
5	T0555A	FUEL LINE	1
6	TRA3057100	IN LINE FUEL FILTER	1
7	T03027	TANK CHECK VALVE	1
8	P356-25	25 PSI CHECK VALVE	1
9	05300265	TEMPERATURE VALVE	1



# SECTION 6



Figure 6-9 Control Panel

Item	Part Number	Description	Quantity
1	MS24523-22	SWITCH	3
2	05300137	MAGNETIC CABINET LATCH	1
3	05300309	INDICATOR LIGHT- GREEN	5
4	MIL-M-3971/1-1	HOUR METER	1
5	05300250	PRESSURE GAUGE	1
6	04100178	PANEL LIGHT	1
7	TR3276	DISCHARGE TEMPERATURE GAUGE	1
8	05300301	LOCKOUT LIGHT- RED	1
9a	05300350	THERMOSTAT 12 VOLT DC	1
9b	05300370	THERMOSTAT KNOB	1

# AEROTECH HERMAN NELSON ACCESSORIES



**Stack Extension**



**Pintle Hitch**



**Fire Extinguisher**



**Amber Strobe Light  
Magnet Base**



**10" Swivel Wheel  
Assembly**



**12" TO 3 X 6" DUCT  
ADAPTER (BUG EYE)**



**6" DUCT  
ADAPTER PLUG**



**12" X 15' 3 PIN J-LOCK  
VINYL DUCT  
Part #TD012HT**



# AEROTECH HERMAN NELSON DUCTS

We offer a complete line of ducting products to meet your industrial heating requirements. Specialty fabrics are utilized to create products capable of delivering indirect-fired preheated air from ground heating equipment to various shelters and equipment.

Applications include industrial, commercial and residential work area heating, equipment heating, special events, drying, construction curing and more.

## SPECIFICATIONS

Diameter Range	6" & 12"
Standard Length	15'
Standard Color	Black (with Grey High-Heat Starter)
Temperature Rating	-65 to 375 °F (-53 TO 190 °C)
Standard End Finish	3 PIN J-LOCK

AEROTECH HERMAN NELSON  
**RECOMMENDED PARTS**

As the BT400NEX-D heater is designed to work under extreme conditions and the following maintenance schedule listed below will help to prolong the life of your Herman Nelson BT400NEX-D heater.

PART NUMBER	DESCRIPTION	QUANTITY	REPLACE
1A30	FUEL FILTER ELEMENT	1	3 MONTHS
KUB13901-41350	FUEL FILTER KUBOTA OC60	1	12 MONTHS
KUB11420-11180	AIR FILTER KUBOTA OC60	1	12 MONTHS
KUB14911-32110	OIL FILTER KUBOTA OC60	1	12 MONTHS
MS15290	FAN BELT	1	12 MONTHS
TO3027	CHECK VALVE (TANK)	1	24 MONTHS
TM3917-2	SLEEVE COUPLING	1	12 MONTHS
TR778	FUEL NOZZLE (DIESEL)	1	12 MONTHS
TRA3057-100	IN-LINE FUEL FILTER	1	12 MONTHS

**DUCT ADAPTER**

The Duct adapter is a fantastic accessories to mutiple the heating capacity of the BT-400NEX-D. The proper way to use this application is first attach ducting to the appliance and then adding the bug eye adapter to the end of the ducting attached to the heater. From here we can add an additional 3 ducts as show in the image to the right of this text.

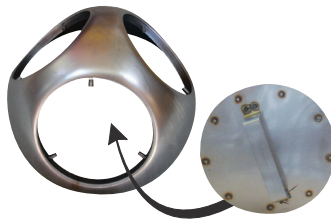

12 inch to 6 inch 3 way  
 Duct Adapter  
 Product #: FT921



1. Warranty terms and conditions are stipulated in the limited product warranty. (i.e., 1 year limited warranty excluding labour.)
2. All claims for warranty must include the following information:
  - Description of the failed part; part number where available.
  - Unit model number and serial number.
  - Date of service and shipment

## CLAIMS WITH INCORRECT OR INSUFFICIENT DATA WILL NOT BE PROCESSED

3. Warranty parts will be issued by Aerotech Herman Nelson Intl. Inc. on a F.O.B. factory basis. Upon return and inspection of the defective part, a replacement (or under certain situations a repaired) part will be shipped "collect" to the authorized Aerotech Herman Nelson Intl. Inc. distributor. Credit will be issued only in certain situations, and must be authorized by the product or service manager. Warranty parts must be returned within 90 days of failure.
4. A Return Goods Tag issued by the manufacturer or an appropriate equivalent is to be completed and returned with the defective part. One tag per part is required.
5. All warranty parts are to be returned "freight prepaid". "Collect" shipments will be returned to the customer. Warranty return packages should be marked and the bill of lading must indicate "warranty return item(s)"
6. To qualify for warranty, the customer account must be current. When an account is in arrears, warranty parts are available on a C.O.D basis only. A warranty credit, when issued, will then be applied against the outstanding account balance.
7. At the discretion of the Product of Service Manager, authorization to "field scrap" parts may be issued. The Return Goods Tag must be forwarded to Aerotech Herman Nelson Intl. Inc. for all "field scrapped" parts.
8. When warranty parts are obtained from a local source, the defective part must be returned with a Return Goods Tag. A credit for the part will be issued for warranty items. The amount of credit will be the current factory replacement cost.





## Contact Aerotech Herman Nelson

### HOW TO GET HELP

Please have the model and serial number on-hand when calling

100 Eagle Drive, Winnipeg, MB, Canada R2R 1V5

Local: 1 (204) 633-1999 (24 hr.)

Toll Free: 1 (800) 486-4328

Fax: 1 (204) 694-1612 or 1(204) 632-4441

Email: [sales@hermannelson.com](mailto:sales@hermannelson.com)

Website: [www.hermannelson.com](http://www.hermannelson.com)



### WARNING

Before operation carefully read this operator's manual to familiarize yourself with the BT400 NEX-D unit

For your own safety and longer product life, follow the instruction notices in this manual.

Keep this Operator Manual and the following manuals in the unit at all times

- Kubota Diesel Engine Operation Manual

Please visit [www.hermannelson.com](http://www.hermannelson.com) for training videos specifically designed to help you better understand how to use your BT 400NEX-D